

Muffler

Removal

NOTE: 4.0L has single muffler, 4.6L and 5.4L have dual mufflers. Repeat steps for both sides, if necessary.

1. With the vehicle in NEUTRAL, position it on a hoist. For additional information, refer to [Section 100-02](#).
2. Loosen the exhaust coupler and disconnect the intermediate pipe from the catalytic converter assembly. Discard the exhaust coupler.
3. Loosen the muffler clamp and disconnect the muffler from the intermediate pipe.

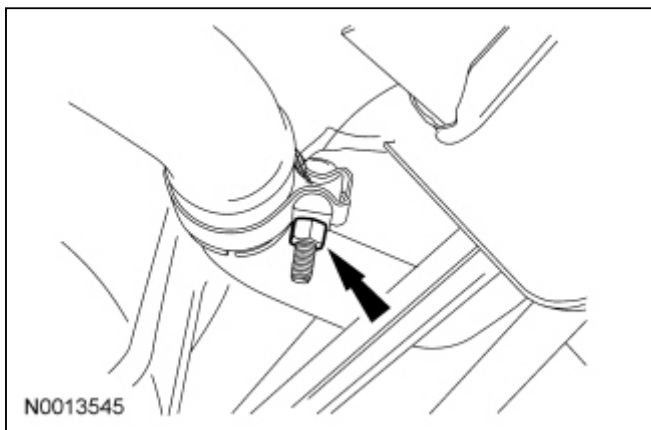

4. Remove the intermediate pipe from the vehicle.
5. Slide the muffler out of the muffler isolators and remove from the vehicle.
 - To install isolators, tighten the bolts to 25 Nm (18 lb-ft).
6. Slide the muffler into the isolators.

Installation

1. Install the intermediate pipe.
2. **NOTE:** Install a new exhaust clamp.

Connect the intermediate pipe into the muffler.
3. Tighten the exhaust clamp.
 - The exhaust clamp should be installed so that it is up to, but not over, the bottom of the notches.
 - Tighten to 48 Nm (35 lb-ft).

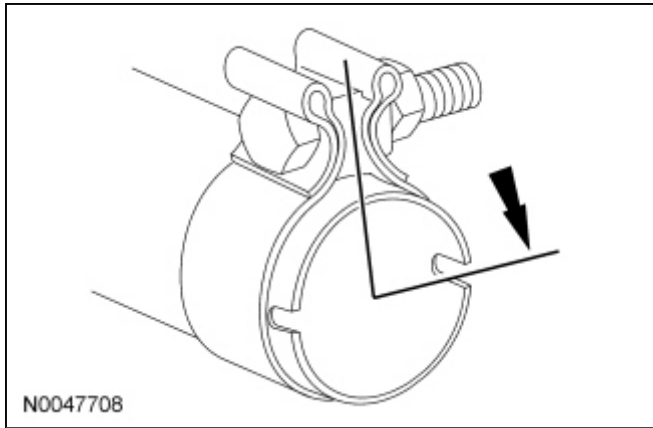

4. Place the new exhaust coupler over the intermediate pipe. Position the intermediate pipe to the catalytic converter, slide the coupler into position until the converter button is seated into the intermediate pipe notch.
5. Push the muffler forward to fully seat the pipe in the coupler.
 - Verify that the intermediate pipe is inserted into the coupler correctly. Correct installation is achieved when the coupler terminates in the knurled region of the intermediate pipe. The knurled section on the intermediate pipe must be at the coupler lip.

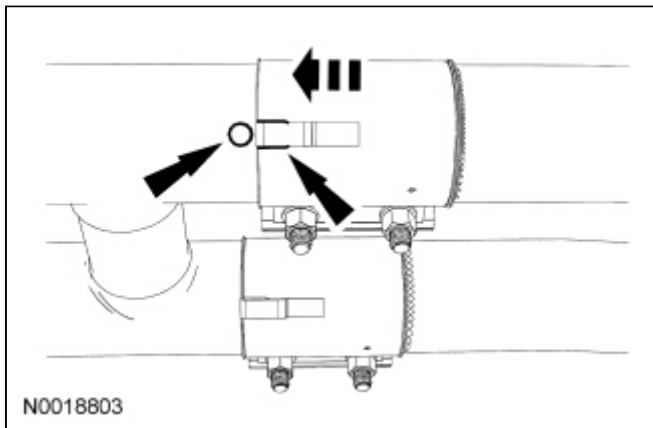

6. Tighten the exhaust coupler nuts.
 - Tighten to 48 Nm (35 lb-ft).
 - Alternately tighten, in 10 Nm (89 lb-in) increments.
-

